

VEGA PICKER

Automatic separating machine for tangled work.

The VEGA PICKER can be loaded by monorail, laundry trolley or by conveyor coming direct from a tumbler system.

As standard the machine includes a transport conveyor to take the linen batch below the two gripping heads and a bypass conveyor to take work through the machine without separating.

After separating, sheets can either be conveyed into a laundry trolley or directly to a sheet feeding machine operators.

The two gripping heads have adjustable clamping pressure and are driven by an inverter drive system which can cycle at an approximate rate of approximately 1.000 cycles per hour.

The effecting lifting height of the articles is over 2.900mm, meaning that not only are the sheets separated but tangling is also reduced.

A PLC control system is fitted with a standalone display panel which can be programmed so that the machine starts as soon as work arrives at the picker. All conveyors can also be controlled by the VEGA PICKER control system.

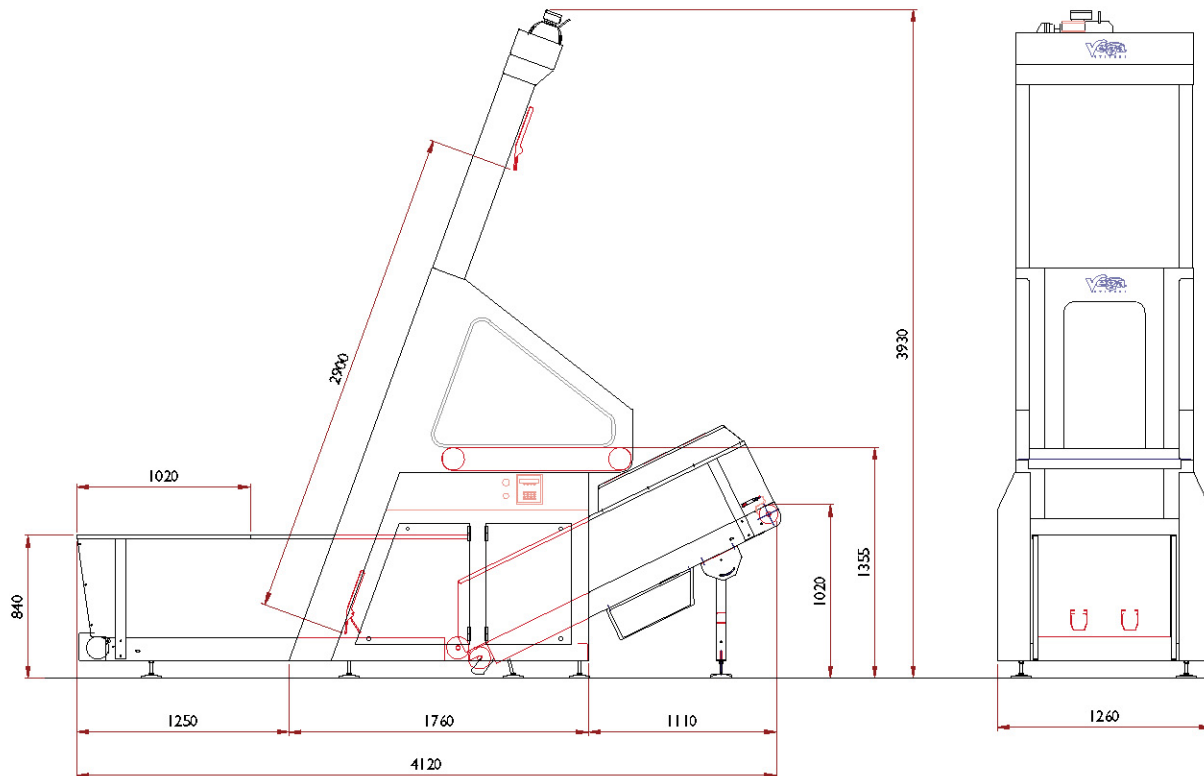
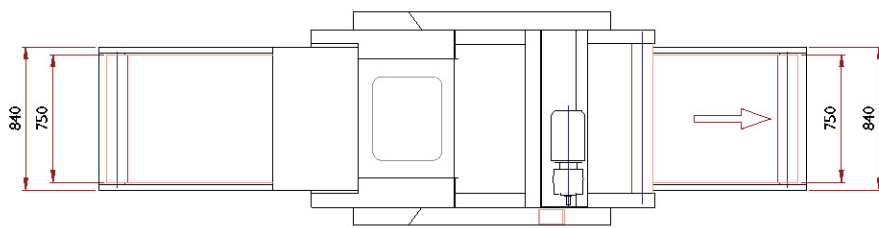

DIMENSIONS:

Loading conveyor width	: 750 mm
By-pass conveyor width	: 750 mm
Maximum Lifting height	: 2.900 mm

TECHNICAL SPECIFICATIONS:

Electric connection	: 3 x 400V + 0 + E, 50 Hz.
Electric consumption	: 2,5 kW, 16 Amp.
Pneumatic connection	: 1/2 ", 6 bar
Pneumatic consumption	: 2 litres / piece.

OPTIONAL:

- Different lifting heights.
- Optional loading conveyors.
- Optional discharge and delivery conveyors.

INSTALLATION AND SERVICE:

Please contact VEGA-systems for more detailed lay-outs and technical data required for installation and service.



VEGA-systems B.V.
 Dommelstraat 37
 5347 JK Oss, The Netherlands
 Phone +31 (0)412 407090
 Fax +31 (0)412 407091
 info@vegasystems.nl