



**Maximum Performance**



## **UDR250 - 285 - 345**

### **FEATURES AND BENEFITS**

- Standard stainless steel drum with large diameter
- Easy-to-use microprocessor (ECT)
- Innovative bulged drum
- Combination of radial and axial airflow
  - maximal heat transfer
  - low energy consumption
  - short drying time
- Large door opening for easy loading and unloading
- Self cleaning lint screen

### **OPTIONS**

- Reversing drum
- Full control programmer
- Residual moisture control:
  - Safe drying of delicate linen
  - Humidity detection in %
  - Ideal for fire departments
  - Available on Easy and Full Control
- Stainless steel front

**INDUSTRIAL TUMBLE DRYER**

TYPE		UDR250	UDR285	UDR345
<b>CAPACITY</b>				
Capacity	kg	11	13	16
Drum volume	l	250	285	345
Drum diameter	Ø mm	760	760	760
<b>DRYING PERFORMANCE</b>				
Airflow	l/s	520	550	600
Drying average	l/min	0,166 (EL) / 0,187 (G)	0,206 (EL) / 0,223 (G)	0,260 (EL) / 0,270 (G)
<b>MOTOR</b>				
Fan	kW	0,55	0,55	0,55
Drive	kW	0,25	0,25	0,25
<b>GAS HEATING</b>				
Energy	kW	16,5	19,5	25
Energy	kBTU/h	56,3	66,5	85,3
Electrical connection		3x220-240V 50Hz, 1x220-240V 50Hz, 3x380-415V 50Hz	3x220-240V 50Hz, 1x220-240V 50Hz, 3x380-415V 50Hz	3x220-240V 50Hz, 1x220-240V 50Hz, 3x380-415V 50Hz
Gas connection	inch	3/4"	3/4"	3/4"
<b>ELECTRICAL HEATING</b>				
Energy	kW	13,5	18,0	24,0
Electrical connection		3x220-240V 50Hz, 3x380-415V 50Hz, 3x480V 60Hz	3x220-240V 50Hz, 3x380-415V 50Hz, 3x480V 60Hz	3x220-240V 50Hz, 3x380-415V 50Hz, 3x480V 60Hz
<b>STEAM HEATING</b>				
Electrical connection	mm	3x220-240V 50Hz, 1x220-240V 50Hz, 3x380-415V 50Hz	3x220-240V 50Hz, 1x220-240V 50Hz, 3x380-415V 50Hz	3x220-240V 50Hz, 1x220-240V 50Hz, 3x380-415V 50Hz
Steam Connection (NPT)	inch	3/4"	3/4"	3/4"
Steam output (*)	kW	16,5-22	19,5-27	22-32
Steam pressure	bar	3-6/7-10	3-6/7-10	3-6/7-10
<b>PROGRAMMER</b>				
Easy Control with antivandal (ECT)		Standard	Standard	Standard
Full Control		Available	Available	Available
<b>DIMENSIONS</b>				
H×W×D	mm	1680 x 795 x 1070	1680 x 795 x 1240	1680 x 795 x 1280
Net weight	kg	230	250	250
<b>TRANSPORT DATA</b>				
Packed H×W×D	mm	1785 x 855 x 1100	1785 x 855 x 1190	1785 x 855 x 1310
Gross weight	kg	240	265	270

1. \* Steam output is flexible depending on steam pressure, The data concerning dimensions of machines include all extended parts

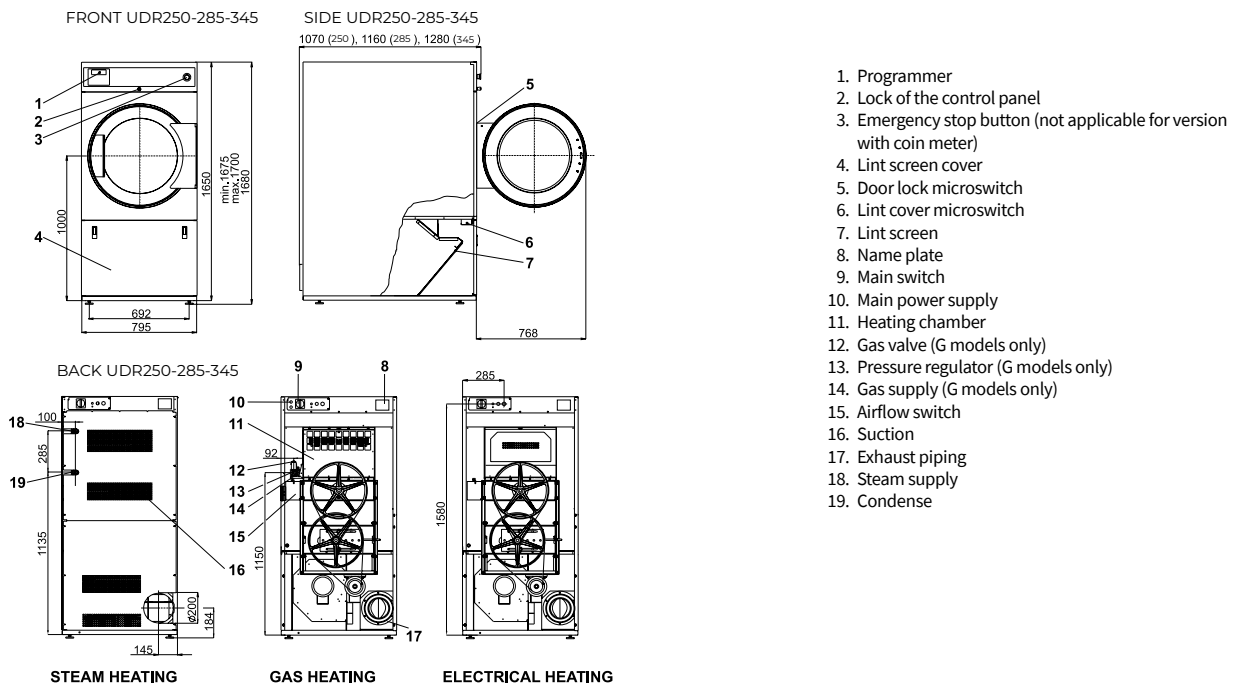

**TO LEARN MORE, OR TO FIND A DISTRIBUTOR IN YOUR AREA, VISIT UNIMAC.COM**  
**ALLIANCE LAUNDRY SYSTEMS - SHEPARD ST, RIPON WI 54971 - +1 800 587 5458**

Consult your UniMac® distributor for details. For the most accurate information, the installation guide should be used for all design and construction purposes. Due to continuous product improvements, design and specifications subject to change without notice. The quality management systems at Alliance Laundry Systems® Ripon facility has been registered to ISO 9001:2008.

©2020 Alliance Laundry Systems LLC.

UniMac® by Alliance Laundry Systems